

**SPLINE DETAILS:  
 23 TEETH  
 24/48 D.P.  
 45° P.A.**

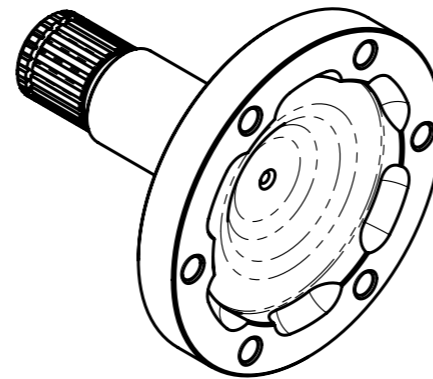

TITLE DRIVE FLANGE	
SCALE 1:1 U.O.S.	SHEET 1 OF 1
<b>Drg. No. F-7Z4-32A</b>	

FINISH. MACH, All Over GRIND@G
LIMITS. FRACT. ± 1/64".
DEC. ± 0.005".
MATERIAL.
TREATMENT.
ISSUE. 01 DATE. 1.9.05
DRAWN BY. J.P.D.
<b>Used In.</b> QUAIPE FIESTA/ESCORT DIFF

IF IN DOUBT, ASK.

**Quaife Design & Development.**

THIS DRAWING OR DESIGN IS STRICTLY  
 CONFIDENTIAL & THE COPYRIGHT THEREIN  
 IS THE EXCLUSIVE PROPERTY OF  
 R.T. QUAIPE ENGINEERING LTD.  
 AND MAY NOT BE USED, COPIED OR EXHIBITED  
 WITHOUT THEIR WRITTEN PERMISSION.